

Precitech, Inc.

Microfinish[®] 300

CNC ASPHERIC LENS POLISHING MACHINE

MACHINE SPECIFICATION

REVISION 6

Microfinish 300 Machine Specification Rev 6

1 MACHINE DESCRIPTION

The Microfinish 300 is a CNC machine designed for the rapid polishing and corrective figuring of aspheric and spherical shapes in rotationally symmetric components such as optical glass lenses, telescope reflector surfaces, Schmidt corrector plates, and other components. The surfaces to be polished may be concave or convex surfaces with up to 90 degrees of included angle, up to 75 mm of sag, and up to 300 mm in diameter. The process is iterative, correcting the polishing program automatically using feedback from a Form Taly surf or Talycontour instrument.

2 ARRANGEMENT OF AXES

Referring to (Figure 1), the part to be polished is mounted on the vertical axis work spindle. The polishing head or tool is moved in X (horizontally), Z (vertically), and B (rotation about the Y direction).

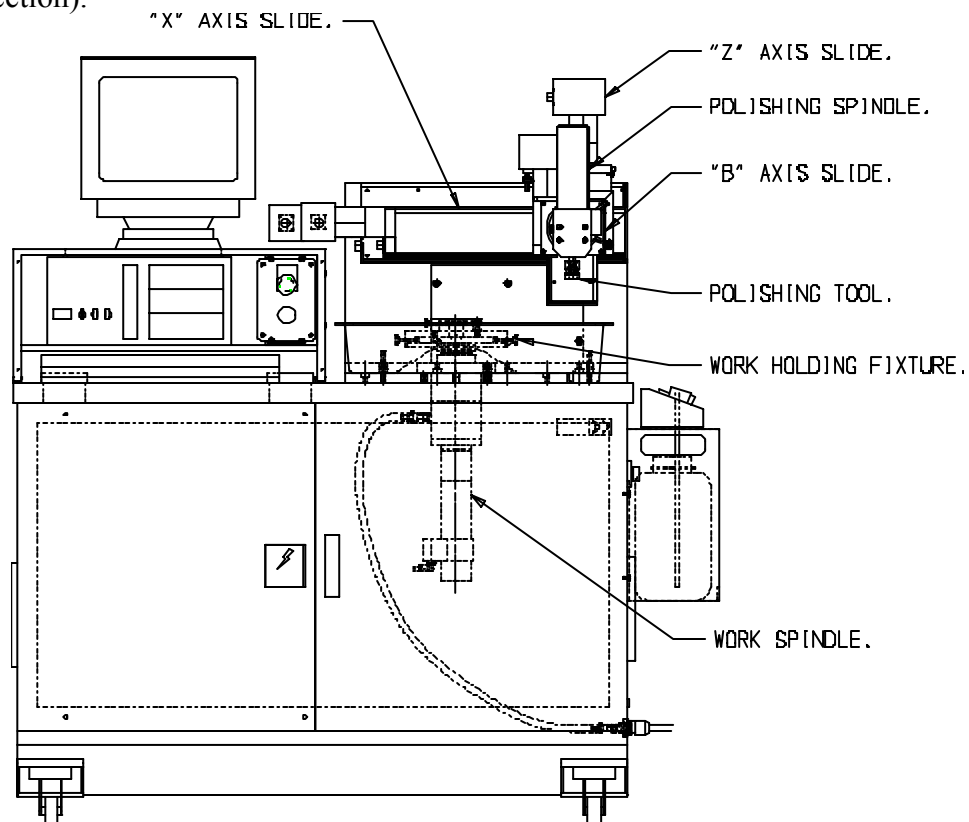

3 X AXIS

The X axis is a cross roller slide with 250 mm (10 inches) of travel. It is driven with a servo motor with rotary encoder position feedback. There are over travel limit switches at each end of travel and a home switch for homing the axis. The slide ways are protected using flexible bellows covers.

4 Z AXIS

Microfinish 300 Machine Specification Rev 6

The Z axis is a cross roller slide with 100 mm (4 inches) of travel. It is driven with a servo motor with rotary encoder position feedback. There are over travel limit switches at each end of travel. The slide ways are protected using flexible bellows covers.

5 B AXIS

The B axis is a rotation axis with +/- 60 degrees of travel from vertical. It is driven with a servo motor with rotary encoder position feedback. There are over travel limit switches at each end of travel.

6 WORK HOLDING SPINDLE

The work spindle is a bidirectional ball bearing spindle with both labyrinth and lip seals protecting the bearings from the polishing slurry. The speed is continuously variable from near zero to 200 RPM.

7 POLISHING HEAD SPINDLE

The polishing head or tool spindle is a ball bearing spindle with a lip seal protecting the bearings from the polishing slurry. The speed is continuously variable from near zero to 200 RPM. The polishing tool is mounted to the spindle manually without the use of tools.

8 MECHANICAL FIXTURE.

This provides an adapter to mount parts requiring polishing to the work spindle.

9 SLURRY SUPPLY SYSTEM

A polishing slurry supply system is included with the machine. It includes a reservoir, agitator, pump, supply line to the polishing head, and variable speed pump motor controls.

10 SAFETY FEATURES, GUARDS AND COVERS

This equipment shall conform to the requirements of the American Occupational Safety and Health Act, as well as the European CE marking directive. Covers and guards are provided to protect the operator from dangerous conditions such as high voltages.

11 CONTROLLER

The software for the operation of the machine tool resides on an IBM-compatible personal computer operating in a Windows environment. The controller provides the operator with the means to control both movement and logical control functions of the machine. The user

Microfinish 300 Machine Specification Rev 6

can move or rotate the axes of the machine in coordinated motions either through manual jogging or programmed motion profiles. The controller also indicates machine faults and axes status. The minimum programmable linear increment is 0.001 mm (1 micron). The maximum slide velocity is 500 mmpm. LPT and COM computer interface ports are provided for interfacing to other equipment. One full open slot is provided for network interfacing.

Part motion profiles are specific to this machine and are generated from blueprint information. (Programs can not be copied from other machine part programs.) Programs are created, stored and accessed internally.

The machine is operated by entering the aspheric data, installing the polishing tool, installing the part, probing the part surface to set up the vertical axis position, moving the axes to the start of polish position, and then running the program. Display information includes the slide positions, part positions, force of polish, and elapsed time. The program allows a file of output data from a Form Talysurf instrument to be added to the part program, to correct for errors that are measured using the FTS.

12 MACHINE PERFORMANCE / CUSTOMER ACCEPTANCE

Machine acceptance at Precitech will be done in accordance with standard Precitech acceptance test procedures. A 50 mm diameter test part pre-ground with the aspheric shape will be polished to qualify the overall machine performance accuracy. The surface is a convex Cartesian oval hyperbola with approximately 5.0 mm sag. The figure error allowed is 0.50 micron P-V over a 44 mm aperture measured on a Form Talysurf instrument. The surface finish specification is 2.5 nanometers (25 Angstroms) RMS as measured on a Talystep instrument with 0.1 micron stylus radius, 4 mg stylus loading, and with a scan length of 50 microns, or equivalent optical surface finish inspection equipment.

13 MANUAL

An operating and maintenance manual is furnished with the machine. A list of recommended spare parts is included in the manual.

14 INSTALLATION & TRAINING

The Precitech service department can provide set-up assistance and training at the customers' facility at additional cost.

15 UTILITIES

110/220 VAC, 50/60 Hz, 1 Phase. Standard power consumption is 2.0 KVA.

Microfinish 300 Machine Specification Rev 6

16 FLOOR SPACE REQUIREMENTS

The floor space necessary for the base machine configuration is approximately 1.0 meter by 2.0 meter (3 feet by 6 feet).

The shipping weight of the standard machine configuration is approximately 450 kg (1000 lbs.).

17 OPTIONAL EQUIPMENT

7.1 Vacuum holding system and Nanoform vacuum chuck adapter

This option consists of a vacuum system and an adapter to allow a part fixtured for a Nanoform 300 or Nanoform 600 machine to be mounted on the work spindle. It includes a vacuum pump, liquid collection reservoir with automatic drain, rotary vacuum joint, Nanoform adapter plate, and pump controls.

7.2 Polisher tools

This option includes a choice of a series of polisher tools for most typical polishing applications.

Contact our marketing department for your specialized needs or for a quote on a unique configuration.

file Microfinish 300 REV 06.doc